

# USER MANUAL



**Model**

**FLH96050SG2**

**FLH96050SG2-H\***

\*Only FLH96050SG2-H has a heating function.

[www.felicitysolar.com](http://www.felicitysolar.com)

# Contents

<b>1. Safety Introductions</b> .....	1
1.1 Warning.....	1
1.1.1 Before Connecting.....	1
1.1.2 During Operation.....	1
1.2 Caution.....	2
1.3 Installation Personnel Requirements.....	3
1.4 Storage Before Use.....	3
<b>2. Transportation</b> .....	4
<b>3. Introductions</b> .....	5
3.1 Symbol Definition.....	5
3.2 Brief Introduction.....	5
3.3 Description of FLH96050SG2/FLH96050SG2-H.....	6
3.4 Features.....	6
3.5 Product Overview.....	6
3.5.1 External Packaging.....	6
3.5.2 Battery System Introduction.....	7
3.5.3 High-Voltage Battery Control Unit Description.....	8
3.5.4 High-Voltage Battery Module Description.....	10
3.5.5 Pedestal Description.....	10
3.6 Product size information.....	11
<b>4.Installation and Configuration</b> .....	12
4.1 Preparations for Installation.....	12
4.1.1 Safety Requirement.....	12
4.1.2 Installation Environment.....	12
4.1.3 Tools.....	12
4.2 Unpacking Inspection.....	13
4.3 Installation Procedure.....	15
4.3.1 Battery Mounting.....	15
4.3.2 Wiring procedure.....	18
4.4 System Connection Diagram.....	19
4.5 Switch on/Off.....	20
4.6 LCD Display Icons.....	22
4.6.1 Main Interface.....	22
4.6.2 Sum Data.....	23
4.6.3 Detail Data1.....	24
4.6.4 Detail Data2.....	24

4.7 Multi-cluster Battery System Connection.....	25
4.7.1 Two battery clusters connected to the inverter.....	25
4.7.2 Three battery clusters connected to the inverter.....	26
4.7.3 Multiple battery clusters connected to the inverter.....	29
<b>5.Heating Function Introduction.....</b>	<b>32</b>
5.1 Detailed Information on the Heating Function Settings Page.....	32
5.2 Operating Guidelines for Heating Function Settings.....	33
5.3 Steps for Heating Mode Configuration.....	33
5.4 Info Prompt During Battery Pack Heating Operation.....	34
<b>6.Network Device Management.....</b>	<b>35</b>
6.1 Network Configuration.....	35
6.1.1 APP Download.....	35
6.1.2 Connect to Built-in Wi-Fi Network.....	35
6.1.3 Network Configuration Steps.....	36
6.2 Plant Creation.....	37
6.2.1 Device Management via APP.....	37
<b>7 Maintenance Troubleshooting.....</b>	<b>39</b>
7.1 Analysis and Treatment of Common Faults.....	39
7.2 Fault Code Table.....	41
<b>8.Battery Recycling.....</b>	<b>42</b>
8.1 Cathode Material Recycling Process and Steps.....	42
8.2 Anode Material Recycling.....	42
8.3 Diaphragm Recycling.....	42
8.4 Recycling Equipment List.....	42
<b>9. Disposal.....</b>	<b>43</b>
<b>Appendix I: Specifications.....</b>	<b>44</b>
<b>Appendix II: Labels.....</b>	<b>45</b>
<b>Appendix III: SN Description.....</b>	<b>47</b>

## Revision History

Revision NO.	Revision Date	Revision Reason
1.0	2025.10	First Published

## About This Manual

The manual mainly describes the introduction, installation, operation, and maintenance. Please read this manual carefully before installing and operating (the product). Keep this manual for future reference.

## How to Use This Manual

Please read this manual and all relevant documents thoroughly before carrying out any operations on the battery, Ensure that the documents are stored securely and are accessible at all times. The content may be revised or updated periodically to reflect product improvements.

## 1. Safety Introductions



### 1.1 WARNING

#### 1.1.1 Before Connecting

- After unpacking, inspect the product and the packing list carefully. If any damage is found or parts are missing, please contact your local retailer for assistance.
- Before installation, be sure to cut off the grid power and make sure the battery is in the turned-off mode.
- Ensure proper wiring by connecting the positive and negative cables correctly and avoiding short circuits with external devices.
- Directly connecting the battery to AC power is strictly prohibited.
- The battery system must be properly grounded, and the grounding resistance should be less than  $1\Omega$ .
- Verify that the electrical parameters of the battery system are fully compatible with the connected equipment.
- Keep the battery away from water and fire.

#### 1.1.2 During Operation

- If the battery system needs to be moved or serviced, ensure that the power is disconnected and the battery is fully powered down.
- Keep the battery away from water and fire.
- Connecting the battery with a different type of battery is strictly prohibited.
- Do not operate the battery with a faulty or incompatible inverter.
- Disassembling the battery is not allowed.
- In the event of a fire, only dry - powder fire extinguishers should be used; liquid fire extinguishers must not be used.
- Please refrain from opening, repairing, or disassembling the battery unless performed by Felicitysolar staff or personnel authorized by Felicitysolar. Any consequences or responsibilities arising from improper operation or violations of design, manufacturing, or equipment safety standards will not be assumed by us.
- Do not dispose of batteries in a fire. The batteries may explode.
- Do not open or mutilate batteries. Released electrolyte is harmful to the skin and eyes. It may be toxic.

- A battery can present a risk of electric shock and burns by high short-circuit current.
- Failed batteries can reach temperatures hot enough to cause burns on contact.



## 1.2 CAUTION

- Our products undergo rigorous inspection before shipment. If you notice any unusual signs, such as the device casing bulging, please contact us promptly.
- **The product must be properly grounded prior to use to ensure safety. This battery pack must be grounded strictly as specified in the product technical manual. Incorrect grounding or poor grounding may lead to safety risks such as electric shock and equipment failure. All losses arising therefrom shall be borne by the party that violates the operation rules.**
- To ensure correct usage, verify that the parameters of connected devices are compatible. Avoid mixing batteries from different manufacturers, types, or models, and avoid using old and new batteries together.
- The ambient environment and storage methods can affect the product's lifespan. Please adhere to the operating environment guidelines to ensure the device functions optimally.
- For long-term storage, recharge the battery every six months, ensuring the charge exceeds 80% of its rated capacity.
- Recharge the battery within 18 hours after it has fully discharged or when over-discharge protection mode is triggered.
- The formula for calculating theoretical standby time is:  $T = C/I$  (where T represents standby time, C is the battery capacity, and I is the total current of all loads).
- Disconnect the charging source prior to connecting or disconnecting battery terminals;
- Do not wear any metal objects including watches and rings;
- Do not lay tools or metal parts on top of batteries; and in addition,
- Battery maintenance must be performed by a skilled person. To do so:
  - Use tools with insulated handles;
  - Wear rubber gloves and boots;
  - Determine if battery is either intentionally or inadvertently grounded. Contact with any part of a grounded battery can result in electric shock and burns by high short-circuit current.
- The risk of such hazards can be reduced if grounds are removed during installation and maintenance by a skilled person.

### 1.3 Installation Personnel Requirements

- All work must comply with applicable local laws, regulations, and standards. Only qualified electricians (see below for qualifications) may install FLH96050SG2/FLH96050SG2-H.
- **Qualifications and Training:** Hold a valid electrician vocational qualification certificate, receive training in the installation, commissioning of electrical equipment and batteries, as well as risk handling, and keep abreast of industry regulation updates.
- **Standard Compliance:** Strictly abide by technical connection conditions, standards, regulations and the requirements of this document, and promptly report any discrepancies between the documents and the actual situation.
- **Professional Knowledge:** Be familiar with the full - process operation of lithium - ion batteries, charging and discharging characteristics, abnormal situation judgment, and understand potential hazard sources.
- **Safety and Emergency Response:** Have a strong sense of safety, use protective equipment correctly, and master first - aid and emergency response skills for electrical accidents and battery leakage.

### 1.4 Storage Before Use

There are no operator serviceable parts in side this equipment. Service should be provided only by a qualified service technician.

- Do not expose battery to open flame.
- Do not place the product in direct sunlight.
- Do not place the product near flammable materials (may cause fire or explosion if an accident occurs).
- Store in a cool, dry, and well-ventilated area.
- Store the product on a flat surface.
- Store the product out of reach of children and animals.
- Do not damage the unit by dropping, deforming, impacting, cutting or penetrating with a sharp object.
- This may cause electrolyte leakage or fire.
- Do not touch any liquid spilled from the product, as it poses a risk of electric shock or skin damage.
- Always handle the battery wearing the insulated gloves.
- Do not step on the product or place any foreign objects on it. This can result in damage
- Do not charge or discharge a damaged battery.

## 2. Transportation

The battery module can only be transported in an upright position.



- Smoking is prohibited in the vehicle during transportation or in the vicinity during loading and unloading



- Dangerous goods transport vehicles must meet relevant road transportation regulations and be equipped with two properly tested CO2 fire extinguishers.



- If possible, do not remove the transport packaging before arrival at the installation site. Before removing the transport protector, check if the transport packaging is damaged.



- Improper transport of battery modules may cause injury. Battery modules could be damaged if they fall or slip. Use only suitable transport/lifting equipment for safe handling.



- Wear safety shoes to avoid injury. Battery modules are heavy, and their parts could crush feet—so all personnel in transport must wear steel-toe safety shoes. Observe safety regulations at the end customer's site, especially during loading/unloading



- During transportation and installation of unpacked battery storage cabinets, the risk of injury increases, especially on sharp metal panels. Therefore, all personnel involved in transportation and installation must wear protective gloves.



















- Improper vehicle transportation can cause injury. Improper transportation or improper transportation locks may cause the load to slip or overturn, resulting in injury.



- Lithium-ion battery transport is classified under hazard category UN3480, Class 9. For transport by sea or land, these batteries fall under Packaging Group PI903, Section II. Use Class 9 'Miscellaneous Dangerous Goods' and UN identification labels when transporting Class 9 lithium-ion batteries. Refer to relevant transport documentation for details.

### 3. Introductions

#### 3.1 Symbol Definition

	Danger! Serious physical injury or death may occur if not following relevant requirements.		Keep the product out of reach of children.
	Caution: Risk of electric shock.		Do not place or install near flammable or explosive materials.
	In case of electrolyte leakage, avoid contact with eyes or skin.		Disconnect the equipment before carrying out maintenance or repair.
	Do not reverse-connect the Pack's positive (+) and negative (-) terminals.		EU WEEE mark: Product should not be disposed of as household waste.
	Observe precautions when handling electrostatic discharge - sensitive devices.		Instruction manual: Read it before starting installation and operation.
	Caution: Risk of electric shock due to timed energy storage discharge.		CE mark: The battery system is CE certified.
	This product is recyclable.	<b>NOTE</b>	NOTE: Procedures to ensure proper operation.
	Do not use the Pack outside of specified conditions.		Earth terminal: The battery system must be reliably grounded to the inverter.
	Caution: This Pack is heavy and may cause serious injury if mishandled.		

#### 3.2 Brief Introduction

FLH96050SG2/FLH96050SG2-H is equipped with a lithium iron phosphate battery designed for household use. Developed based on customer needs and market demands, this advanced battery storage solution provides high-quality, reliable power for various devices. The product features a long lifespan, suitability for high-temperature environments, and a compact design that requires minimal installation space.

FLH96050SG2/FLH96050SG2-H features a battery management system independently developed by our team. When connected to a grid or photovoltaic system as the power source, the product can store energy by charging the battery. In the event of a power outage from the grid or photovoltaic system, the product independently supplies electricity to household loads. Additionally, multiple units can be connected in parallel to form a high-capacity, multi-module system, meeting long-term energy storage requirements. Only the FLH96050SG2-H model supports the heating function. For details about the heating function, please refer to Section 5 "Heating Function Introduction" in the instruction manual.

### 3.3 Description of FLH96050SG2/FLH96050SG2-H

1. FLH96050SMG2/ FLH96050SMG2-H is a battery module, it needs to be used with FLH96050SCG2/FLH96050SCG2-H controller;
2. FLH96050SCG2/FLH96050SCG2-H is the controller of the entire system, so each system has at least five FLH96050SMG2/ FLH96050SMG2-H .
3. Our system consists of at least 1 FLH96050SCG2/FLH96050SCG2-H+2 FLH96050SMG2/ FLH96050SMG2-H and up to 6 FLH96050SMG2/ FLH96050SMG2-H.

Mode	System energy(kWh)	Discharge depth	Composition
FLH96050SG2M2/-H	10.24	90%	FLH96050SCG2/-H*1 + FLH96050SMG2/-H*2
FLH96050SG2M3/-H	15.36	90%	FLH96050SCG2/-H*1 + FLH96050SMG2/-H*3
FLH96050SG2M4/-H	20.48	90%	FLH96050SCG2/-H*1 + FLH96050SMG2/-H*4
FLH96050SG2M5/-H	25.6	90%	FLH96050SCG2/-H*1 + FLH96050SMG2/-H*5
FLH96050SG2M6/-H	30.72	90%	FLH96050SCG2/-H*1 + FLH96050SMG2/-H*6

### 3.4 Features

- LiFePO4: Higher safe performance and longer cycle life.
- Multiple Protection: Built-in smart BMS, Breaker and Fuse.
- Flexible Installation: Floor-Mounted.
- Wide Compatibility: Compatible with leading inverter brands.
- High Scalability: Capacity up to 30.72kWh.
- Built-in WFI/Bluetooth: Remote monitoring of battery pack data.
- IP65 Protection Level: Suitable for Outdoor Use.
- Equipped with an aerosol fire extinguishing system.

### 3.5 Product Overview

#### 3.5.1 External Packaging

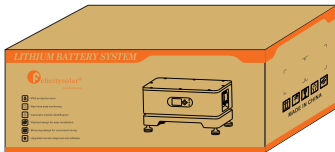

Carton box  
 (FLH96050SCG2//FLH96050SCG2-H)

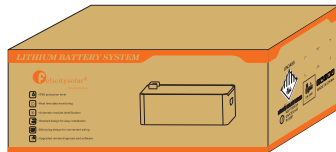

Carton box  
 (FLH96050SMG2/FLH96050SMG2-H)

### 3.5.2 Battery system introduction

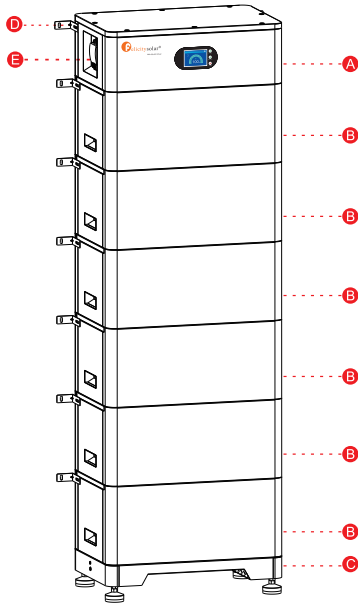

Code	Name
A	High-Voltage Battery Control Unit(BCU)
B	High-Voltage Battery Module(BMU)
C	Pedestal
D	Fixed trestle
E	Safety shield

### 3.5.3 High-Voltage Battery Control Unit Description

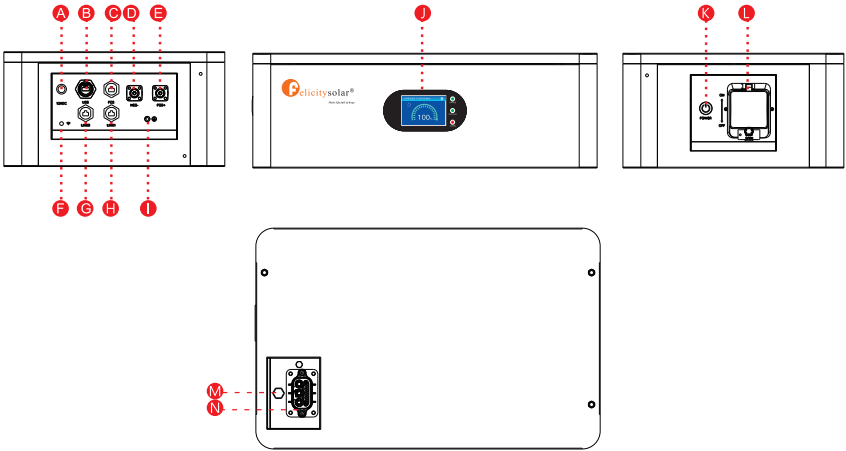

Code	Name	Definition
A	12VDC	Connect with external 12VDC power supply and debug for battery control unit
B	USB	BMS upgrade interface with USB
C	PCS	The clustered interface connected to the previous battery system
D	NEG-	Connection terminal of negative pole(black)
E	POS+	Connection terminal of positive pole(red)
F	WIFI	Increase the WiFi receiving signa
G	LINK0	Connect with the first battery module and communicate with all battery modules
H	LINK1	Connect with the first battery module and communicate with all battery modules
I	PE	Shell ground connection

J	LCD Display	Indicate the important battery information
K	Power Switch	Indicate the power on/off function
L	DC Circuit Breaker	Used to manually control the output situation of battery rack
M	Bleed valve	When the pressure inside the battery pack is too high, the breather valve works to release the pressure to protect the battery pack.
N	Blind plug terminal	The direct connection terminals of the battery pack include communication cables and power cables.

**Link1, Link0 Port Definition**

Picture	Pin	Color	Definition
	1	ORG-WH	NC
	2	ORG	NC
	3	GN-WH	NC
	4	BU	NC
	5	BU-WH	NC
	6	GN	NC
	7	BN-WH	CANH
	8	BN	CANL

**PCS Port Pin Definition**

Battery-Felicity Solar

Picture	Pin	Color	Definition
	1	ORG-WH	485B
	2	ORG	485A
	3	GN-WH	GND
	4	BU	CANH
	5	BU-WH	CANL
	6	GN	GND
	7	BN-WH	485A
	8	BN	485B

Inverter-Felicity Solar

Pin	Color	Definition	Picture
1	ORG-WH	/	
2	ORG	/	
3	GN-WH	/	
4	BU	CANH	
5	BU-WH	CANL	
6	GN	GND	
7	BN-WH	485A	
8	BN	485B	



\* If using this product with an inverter from another brand, please confirm the pin definition for the connection between the inverter and the battery.

### 3.5.4 High-Voltage Battery Module Description

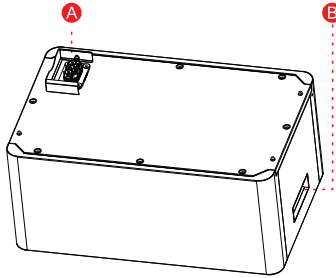

Code	Name	Definition
A	Blind plug terminal	The direct connection terminals of the battery pack include communication cables and power cables.
B	Handle	Handle

### 3.5.5 Pedestal Description

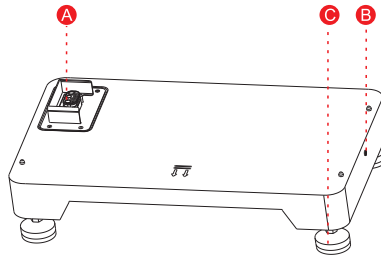

Model: Pedestal

Code	Name	Definition
A	Blind plug terminal	The direct connection terminals of the battery pack include communication cables and power cables.
B	PE	Shell ground connection
C	Foot cup	Foot cup

### 3.6 Product size information

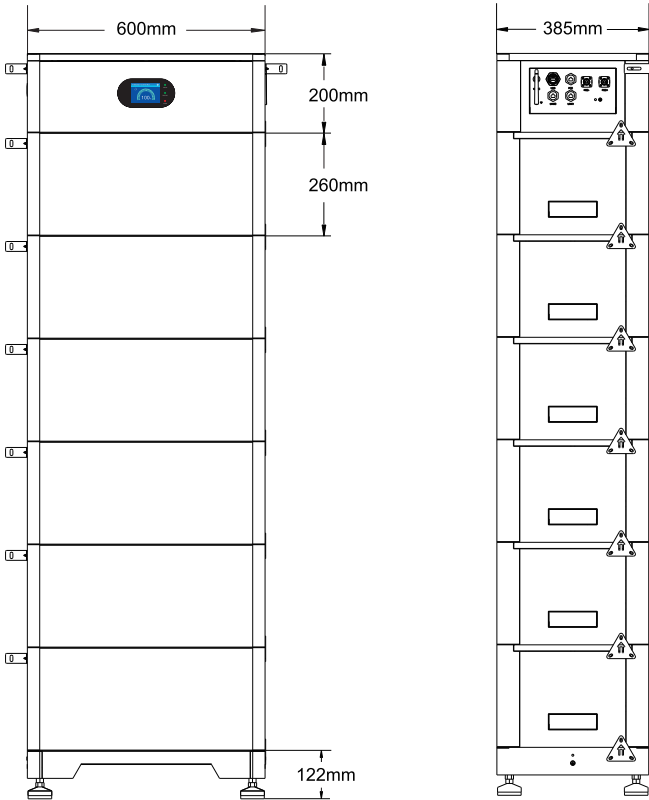

## 4. Installation and Configuration

### 4.1 Preparations for Installation

#### 4.1.1 Safety Requirement

This system must only be installed by personnel trained in power supply systems and possessing adequate knowledge of such systems. The safety guidelines outlined below, along with applicable local safety standards, must be strictly adhered to during installation.

- All circuits interfacing with this power system and carrying external voltages below 48V must comply with SELV requirements as specified in the IEC60950 standard.
- If working within the power system cabinet, ensure the system is completely powered down, and all battery devices are switched off.
- The distribution cables should be arranged systematically and equipped with protective measures to prevent accidental contact while operating power equipment.

#### 4.1.2 Installation Environment

- Working temperature:  $-20^{\circ}\text{C} \sim +55^{\circ}\text{C}$
- Charging temperature range:  $0^{\circ}\text{C} \sim +55^{\circ}\text{C}$
- Discharging temperature range:  $-20^{\circ}\text{C} \sim +55^{\circ}\text{C}$
- Storage temperature:  $0^{\circ}\text{C} \sim +35^{\circ}\text{C}$
- Relative humidity: 5% ~ 95%
- Elevation:  $\leq 2000\text{m}$
- Protective Class: I

Operating environment: Suitable for indoor or outdoor installation at locations shielded from direct sunlight, wind, conductive dust, and corrosive gases.

Ensure the following conditions are met:

- The installation site should be distant from the sea to prevent exposure to saltwater and high humidity.
- The ground at the installation location must be flat and level.
- The site should be free of flammable or explosive materials.
- Optimal ambient temperature:  $20^{\circ}\text{C}$  to  $30^{\circ}\text{C}$ .
- Avoid areas with excessive dust or clutter.

#### 4.1.3 Tools



Screw Driver



Crimping Modular



Safety Shoes



Multimeter



Safety Gloves



Safety Goggles



Plier











Ribbon

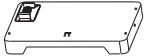









Electric drill





## 4.2 Unpacking Inspection

- Upon arrival at the installation site, loading and unloading should strictly follow the established rules and procedures to prevent exposure to sunlight and rain.
- Before unpacking, verify the total number of packages against the shipping list attached to each package, and inspect the outer cases for any signs of damage. After unpacking, carefully check for loose or damaged wiring and contacts, cracks, deformations, leaks, or any other form of damage. If any damage is detected, the battery must be replaced immediately. Do not attempt to charge or use a damaged battery, and avoid contact with any liquid from a ruptured battery.
- During unpacking, handle all components with care to protect the surface coating from damage.

FLH96050SCG2/FLH96050SCG2-H			
No.	Description	Quantity	Picture
1	High-Voltage Battery Control Unit	1	
2	Pedestal	1	
3	User manual	1	
4	Warranty card	1	
5	Power Cable 1: 5meters, 8.4mm <sup>2</sup> , allows for charging and discharging up to 50A, used to connect to external PCS- (black)	1	
6	Power Cable 2: 5meters, 8.4mm <sup>2</sup> , allows for charging and discharging up to 50A, used to connect to external PCS+ (red)	1	
7	Communication Cable 1: 3meters, use an RS485 adapter to achieve communication between the battery and the computer	1	
8	Communication Cable 2: 3meters, communication between the battery pack and the Felicity inverter	1	
9	Communication Cable 3: 2meters, used for the clustering function	1	
10	Ground Cable: The 2m ground cable is used to connect the inverter to the battery ground	1	

11	Battery Terminal : Connection ports for batteries and inverter Bat Port	2	
12	Magnetic Ring: Improve the electromagnetic anti-interference performance (31x19x30 mm)	1	
13	Screw: Used for installing control cabinet (M5x12*3 PCS)	3	
14	Expansion Plastic Screw: Used together for product fixation	2	
15	BOT Foot Cup: Used for supporting the product	4	
16	Signal Terminal: Used for creating custom communication cables	2	
17	Fixed Trestle : Used for fixing products	2	
18	120Ω Terminal Resistor: Used for BMU communication and parallel communication.	2	

**FLH96050SMG2/FLH96050SMG2-H**

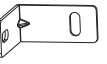
No.	Description	Quantity	Picture
1	High-Voltage Battery Module	1	
2	Warranty card	1	
3	Expansion Plastic Screw: used together for product fixation.	2	
4	Screw: used for installing battery pack modules. (M5x12*4 PCS).	4	
5	Fix the bracket	1	
6	Fixed trestle: Used for fixing products	2	

### 4.3 Installation Procedure

#### 4.3.1 Battery Mounting

(a) Wall-mounted method

Step 1: Remove the battery, base and control box from the carton.

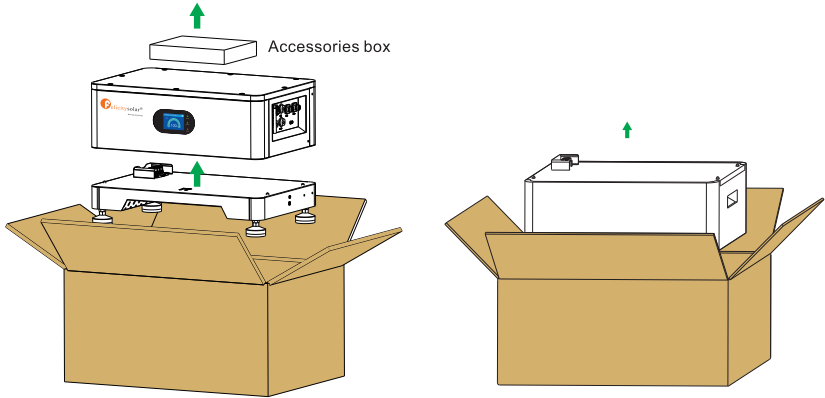

Step 2: Place the base against the wall.

Step 3: Install 1~6 battery boxes on the base, and then place the control box above the installed battery to ensure it is firmly placed.

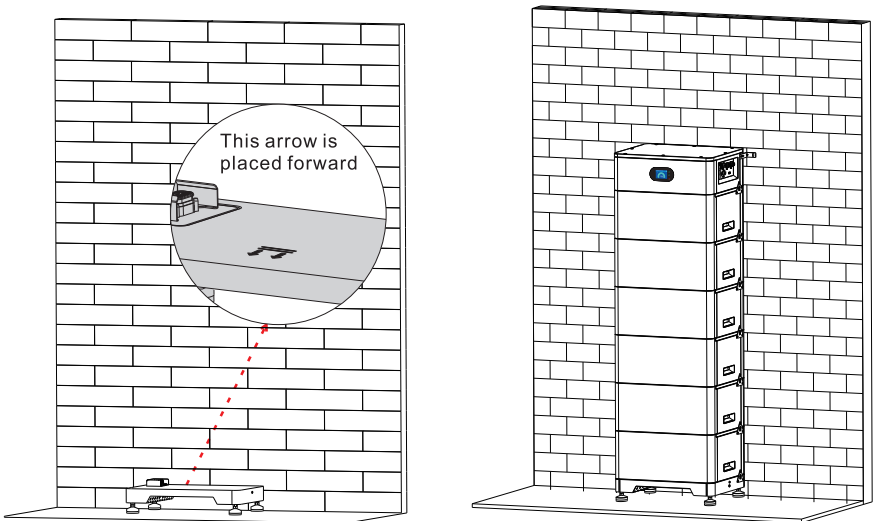

Step 4: install the anti-tipping bracket of the control box, mark the punching position with a marker, and remove the anti-tipping bracket and the control box.

Step 5: Use the impact drill to drill holes. (Aperture: 10mm, depth: 60mm).

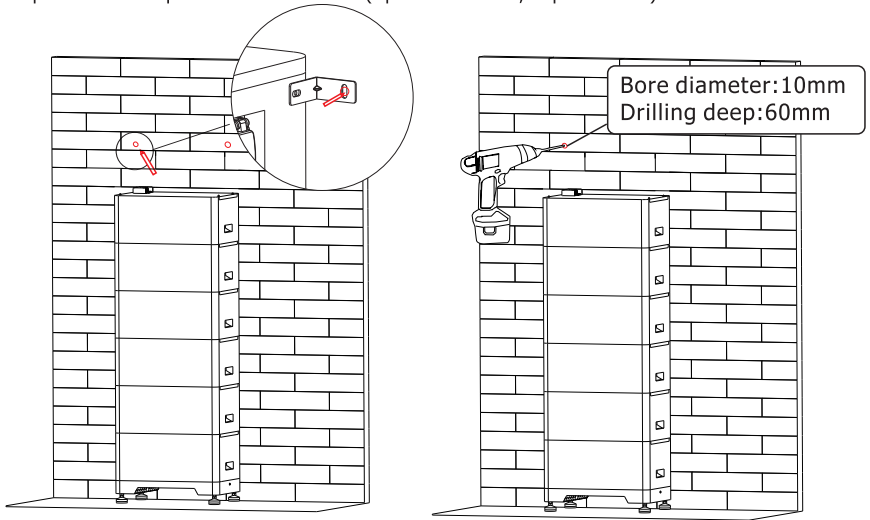

Step 6: Use a hammer to knock the plastic plug into the hole, fit it to the wall, then reinstall the control box and the anti-tipping bracket, and tighten the screws on the anti-tipping bracket. The torque requirement is 10N · m to ensure that the control box is firmly installed.

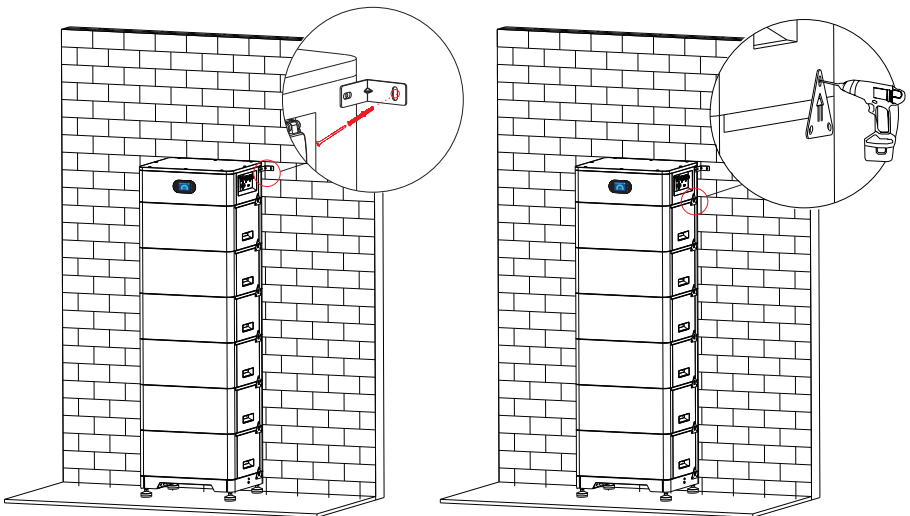

**Note:**

1. Check that the ground is flat and free of tilt before installation.
2. Make sure that the base is vertical and close to the ground.
3. Make sure that the base is against the wall and the arrow direction on the base faces outward when placing.
4. When placing the upper battery, make sure that the upper and lower hole positions are aligned.
5. Be careful of the battery falling.
6. Avoid installing the anti-tipping bracket on the same side.
7. There is no gap between battery packs and battery packs during stack installation. If there is a gap, place the battery pack with the gap on the lower layer.

**(b) Floor-Mounted method**

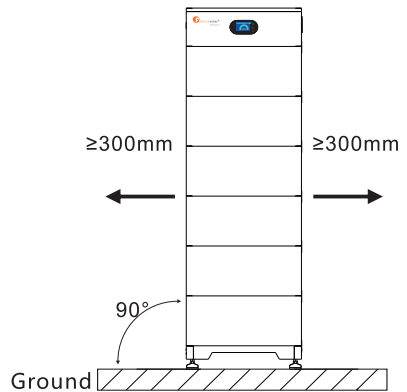
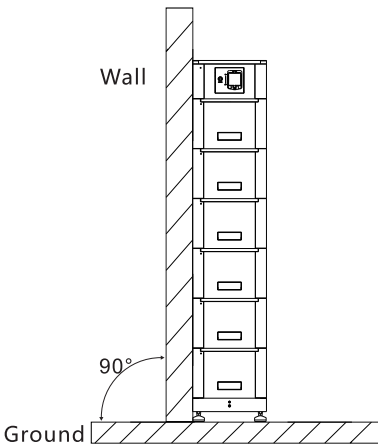
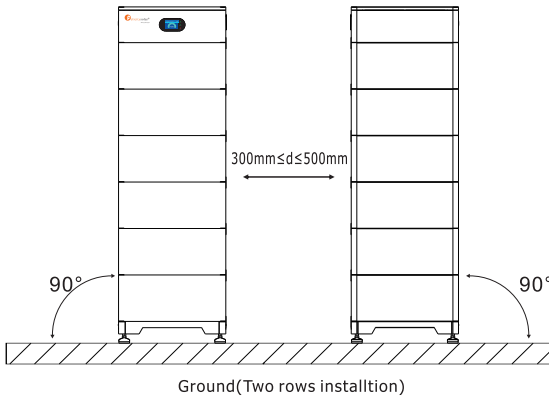

### 4.3.2 Wiring procedure

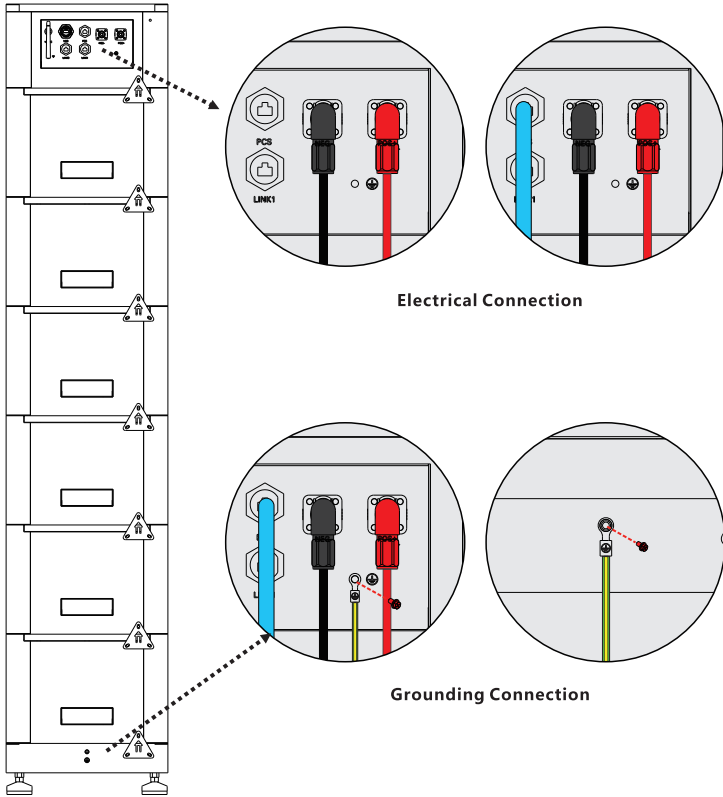

**Electrical Connection**

**Grounding Connection**

### Power terminal Connection

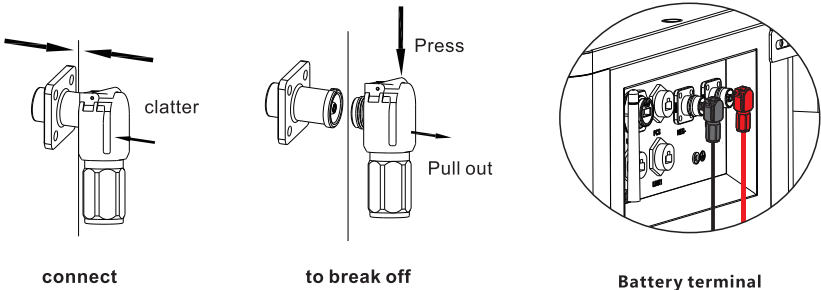

**connect**

**to break off**

**Battery terminal**

### 4.4 System Connection Diagram

- Negative Power Line
- Positive Power Line
- RJ45 485/CAN Communication
- Ground Connection

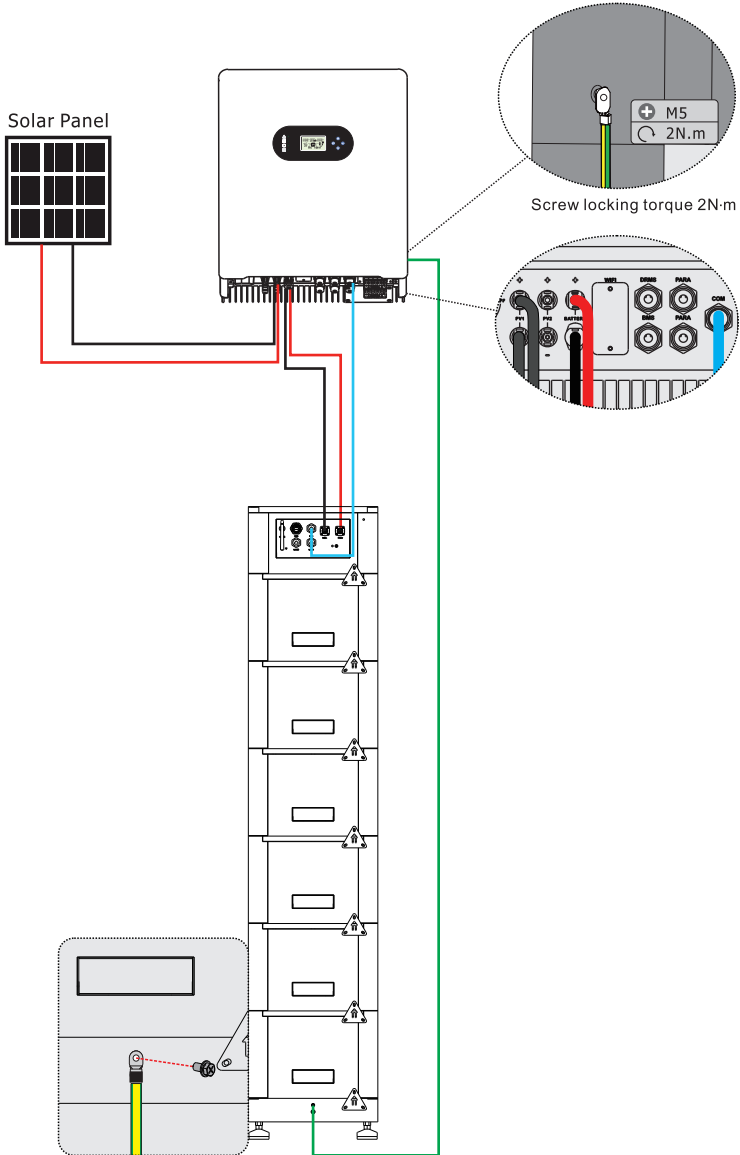

## 4.5 Switch On/Off

### Power on steps:

Step 1: Confirm that the battery and inverter are properly wired, then start the inverter ❶

Step 2: Turn on the battery breaker by switching it from "OFF" to "ON" ❷

Step 3: Press and hold the power button ❸ for 3 seconds to activate the battery system. If the battery clusters are connected in parallel, connect the harnesses in sequence as indicated and then turn on them one by one.

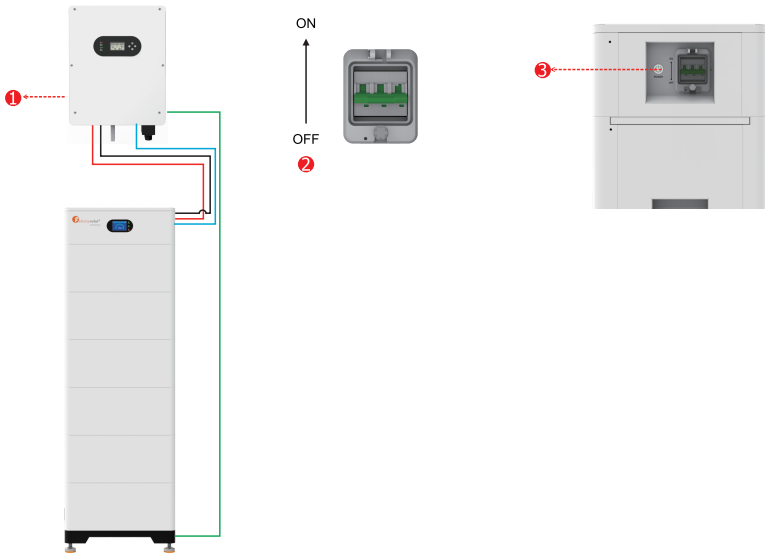

**Power down steps:**

Step 1: Shut down the inverter ❶

Step 2: Press and hold the power button ❷ for 3 seconds to turn off the battery system;

Step 3: Turn off the battery breaker by switching it from "ON" to "OFF" ❸

Note: If batteries are connected in parallel, shut them down one by one.

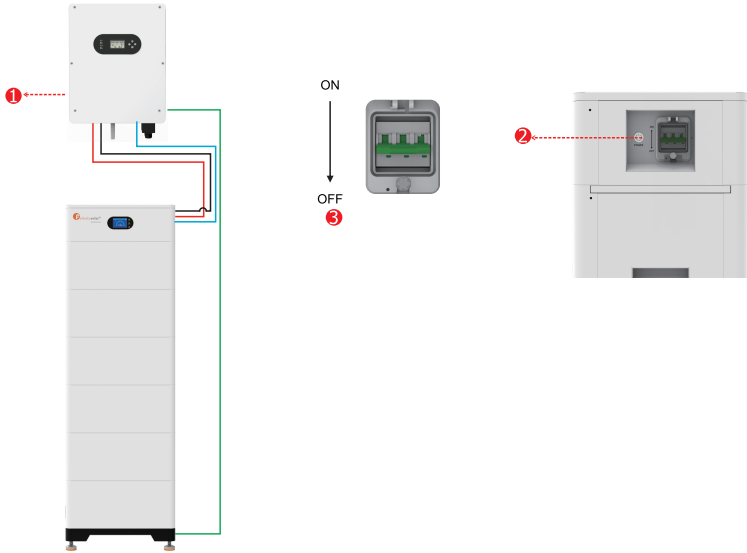

## 4.6 LCD Display Icons

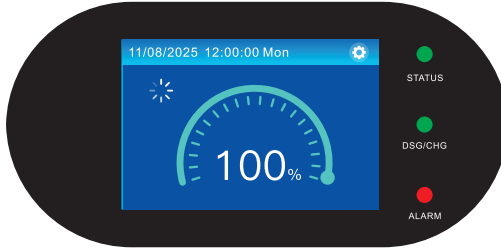

Name	Description
LCD touch screen	Display the information of the battery.
Status LED	Indicates the operating status of the battery, which is always on when running normally.
Charge&Discharge LED	Indicates the charging&discharging status of the battery; A long bright light indicates discharging, and a flashing light indicates charging.
Alarm LED	Indicates the fault status of the battery, which lights up when the fault occurs.

### 4.6.1 Main Interface

Battery Information	
	Indicate SOC.
	It Indicates the battery level, with each grid representing 5%.
	This icon lights up to indicate that the battery is waiting to be connected, and there is no output at this time. After entering normal working mode, this icon disappears.

### 4.6.2 Sum Data

This page displays the summary information of parallel battery system(If it is a single-cluster system, the information displayed is its own):

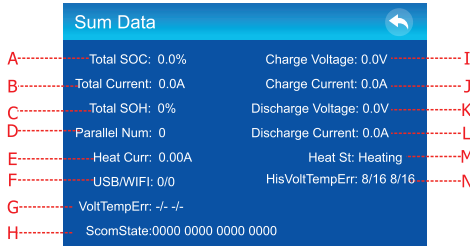

Code	Name	Definition
A	Total SOC	SOC of battery system.
B	Total Current	Total Current of battery system.
C	Total SOH	SOH battery system.
D	Pararrel Number	The number of successfully paralleled batteries.
E	Heat Current	Heat Current of battery system. If this battery does not support the heating function, please ignore it.
F	USB/WIFI	USB/WIFI connection state. 1 represents connected, and 0 represents disconnected.
G	Voltage Temperature Error	Current records of BMU cells or temperatures error
H	Slave Com State	BMU communication state. Binary numbers are used to determine which BMUs are online.
I	Charge Voltage	Charge limited voltage of battery system.
J	Charge Current	Charge limited current of battery system.
K	Discharge Voltage	Discharge limited voltage of battery system.
L	Discharge Current	Discharge limited current of battery system.
M	Heat State	Heat state of battery system. If this battery does not support the heating function, please ignore it.
N	History Voltage Temperature Error	Historical records of battery cells or temperatures;

### 4.6.3 Detail Data1

This page displays the detail information of parallel battery system:

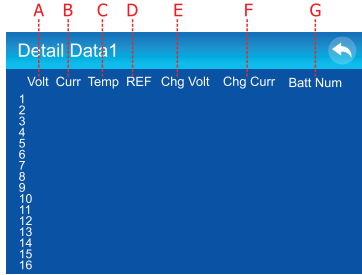

Code	Name	Definition
A	Voltage	Every battety voltage of parallel battery system.
B	Current	Every battety current of parallel battery system.
C	Temperature	Every battety temperature of parallel battery system.
D	Reference SOC	Every battety reference SOC of parallel battery system.
E	Charge Voltage	Every battety charge limited voltage of parallel battery system.
F	Charge Current	Every battety charge limited current of parallel battery system.
G	Battery Number	Battery address number.

### 4.6.4 Detail Data2

This page displays the detail information of battery system:

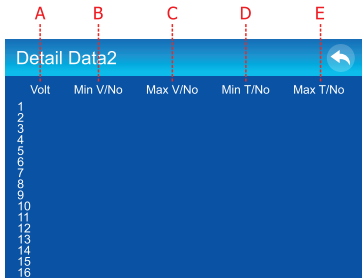

Code	Name	Definition
A	Voltage	Every BMU voltage of battery system.
B	Minimum Voltage/No	Minimum cell voltage of BMU and cell number.
C	Maximum Voltage/No	Maximum cell voltage of BMU cell number.
D	Minimum Temperature/No	Minimum cell temperature of BMU cell number.
E	Maximum Temperature/No	Maximum cell temperature of BMU cell number.

## 4.7 Multi-cluster Battery System Connection

The FLH96050SG2 supports to be connected in parallel for expansion. It can support up to 16 clusters FLH96050SG2 in parallel. Before setting up the parallel system, it is necessary to carefully read this chapter to ensure that the number of each cluster's BMUs is consistent, that the addresses are set correctly, and that the electrical connections are safe and correct.

\*For the specific combiner box model, please consult our after-sales support via:

Email: [felicitysupport@felicitysolar.com](mailto:felicitysupport@felicitysolar.com)

WhatsApp: +86 18022876286

### 4.7.1 Two battery clusters connected to the inverter

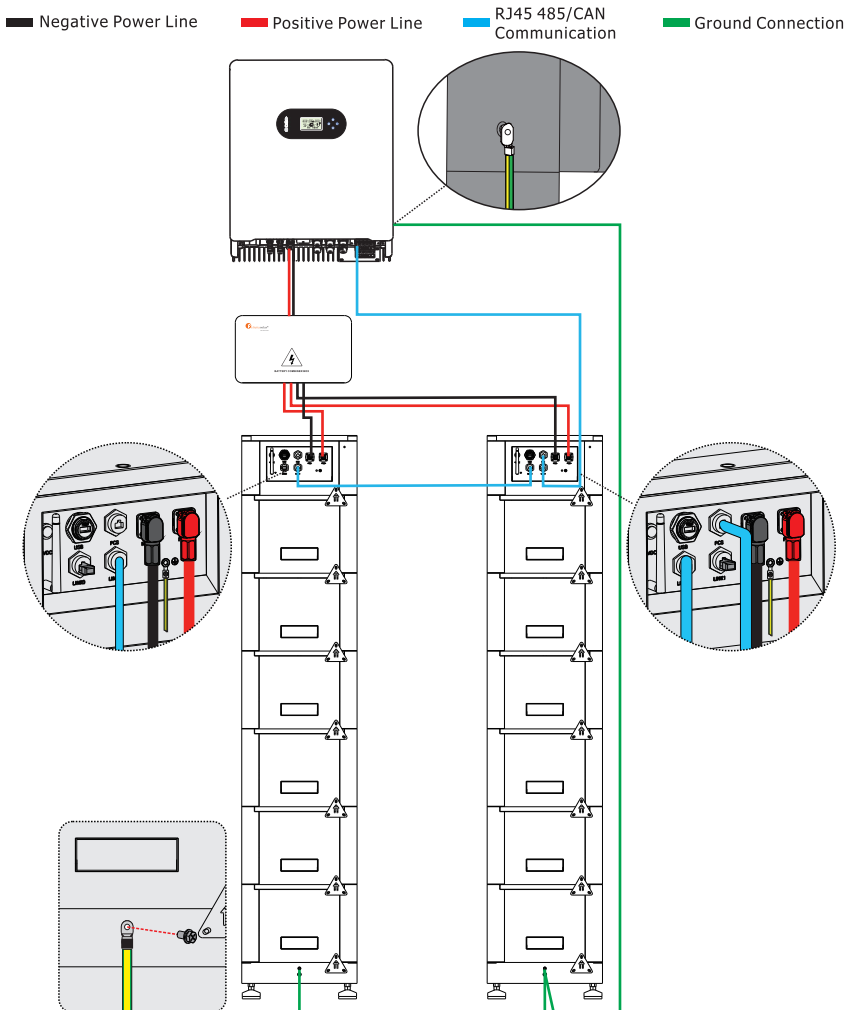

### 4.7.2 Three battery clusters connected to the inverter

#### 1. Wiring Diagram

- Negative Power Line
- Positive Power Line
- RJ45 485/CAN Communication
- Ground Connection

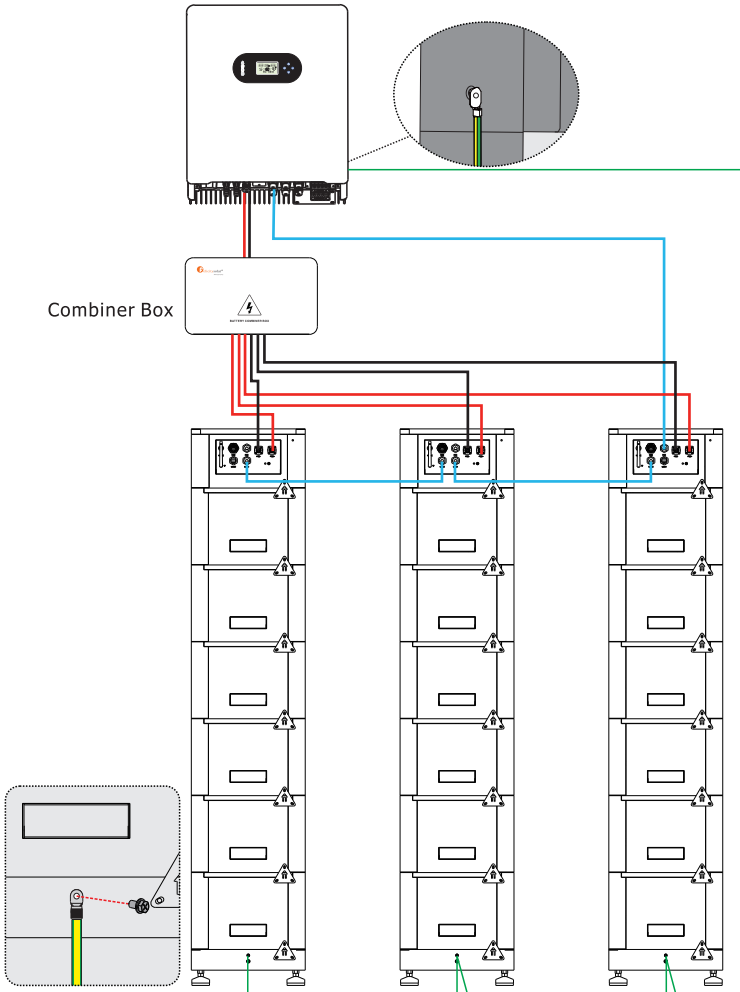

Schematic Diagram of Communication Port Connections

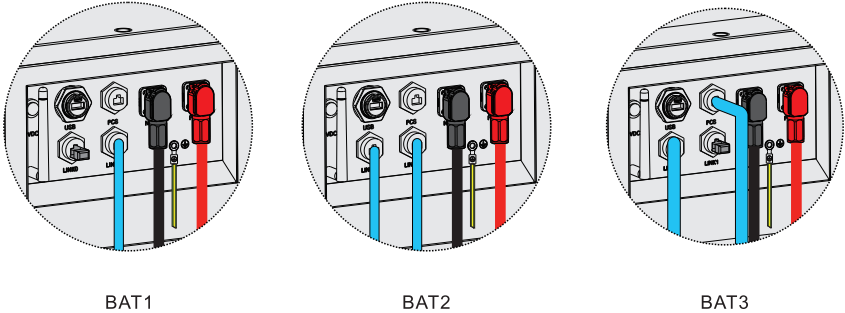

**2. Battery Cluster Configuration Steps**

Prior to system setup, upgrade the main control software and LCD firmware to a version no lower than that shown in the figure. If the program version is lower than the version shown in the picture, please contact the supplier.

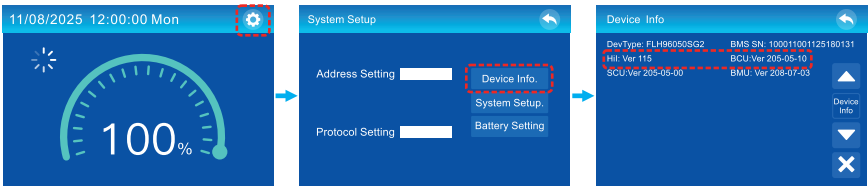

**Battery pack parallel operation address setting:**

1. After connecting the battery cables, power on the battery pack and configure the main control address via the display. Main control addresses must be unique (no duplicates), with a maximum configurable address of 16.
2. Once the address is configured, restart the battery pack.

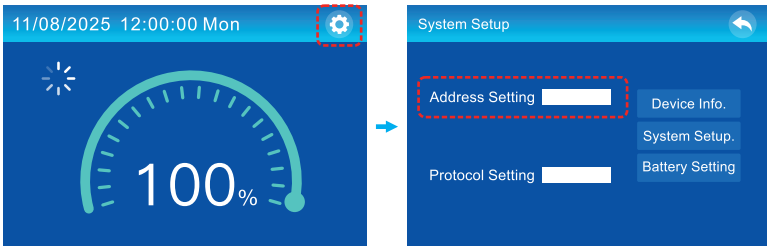

“Protocol Setting”: This feature is currently under development and requires no attention for the time being.

**Parallel SOC Averaging Setting:**

1. After connecting the battery cables, access the "System Setup" page and click "Basic Setting".
2. Check the "REF SOC" option.

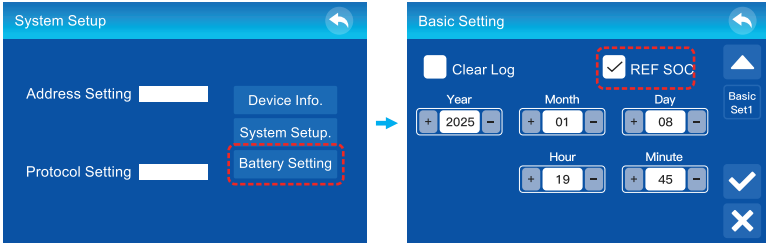

Click "REF SOC"

### 4.7.3 Multiple battery clusters connected to the inverter

#### 1. Wiring Diagram

- Negative Power Line
- Positive Power Line
- RJ45 485/CAN Communication
- Ground Connection

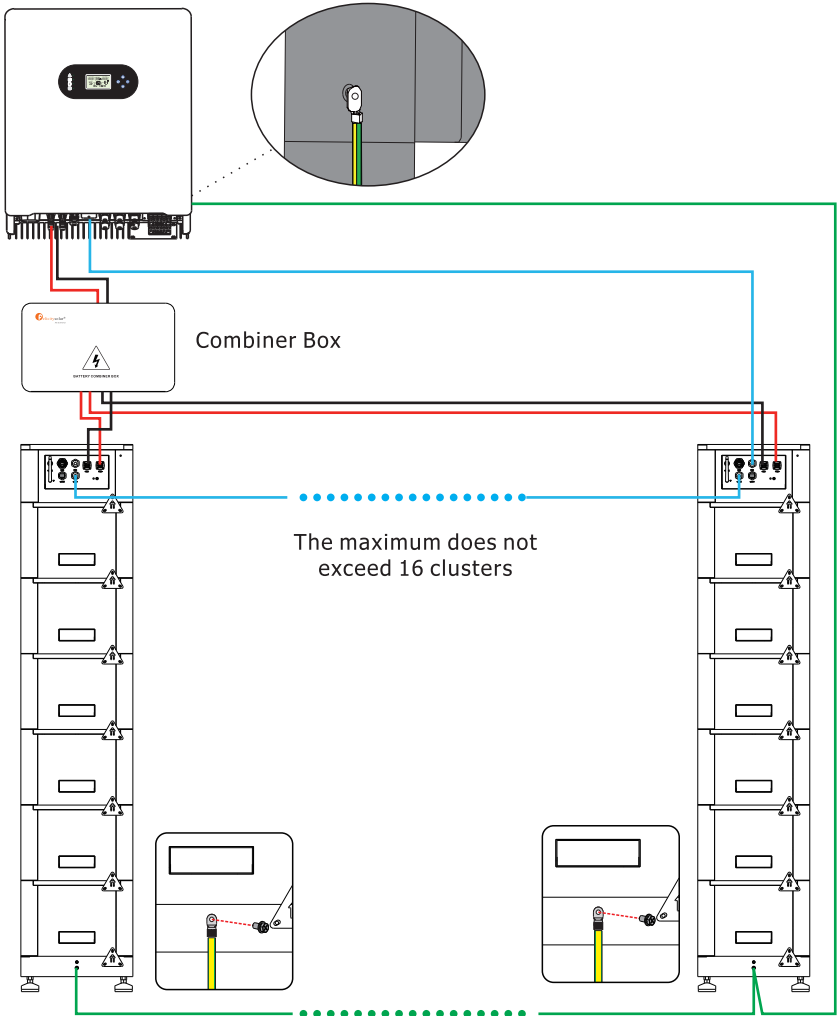

Schematic Diagram of Communication Port Connections

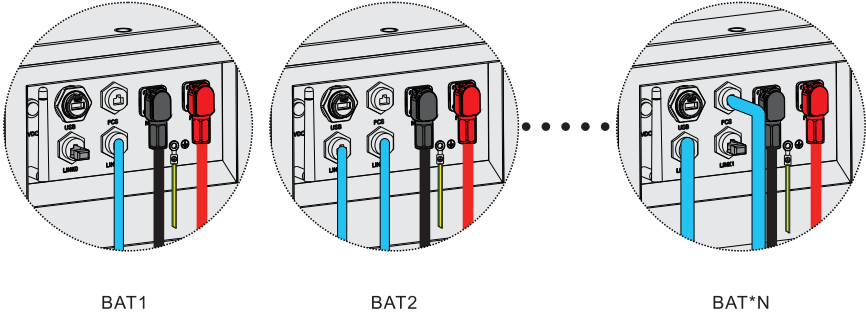

**2. Battery Cluster Configuration Steps**

Prior to system setup, upgrade the main control software and LCD firmware to a version no lower than that shown in the figure. If the program version is lower than the version shown in the picture, please contact the supplier.

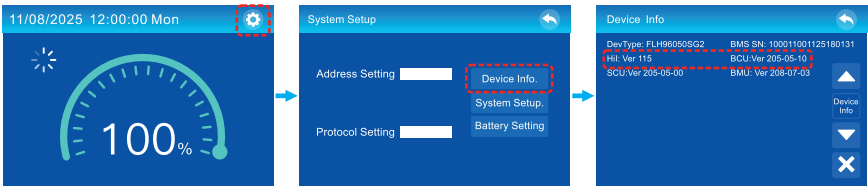

**Battery pack parallel operation address setting:**

1. After connecting the battery cables, power on the battery pack and configure the main control address via the display. Main control addresses must be unique (no duplicates), with a maximum configurable address of 16.
2. Once the address is configured, restart the battery pack.

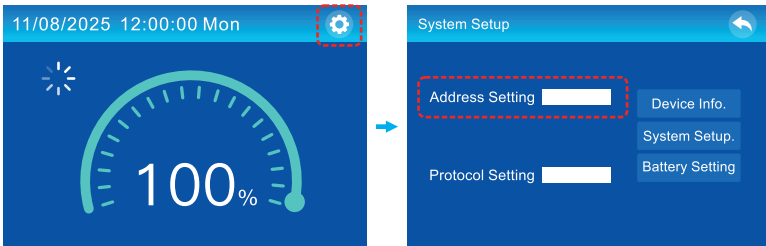

"Protocol Setting": This feature is currently under development and requires no attention for the time being.

### Parallel SOC Averaging Settings

1. After connecting the battery cables, access the "System Setup" page and click "Basic Setting".
2. Check the "REF SOC" option.

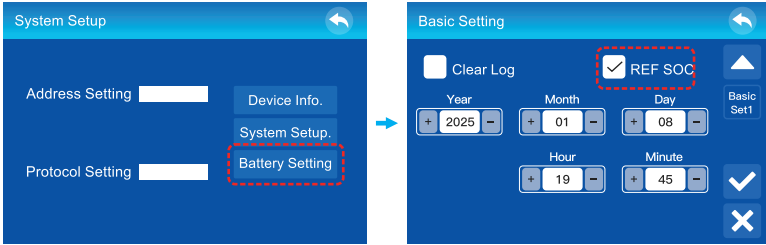

Click "REF SOC"

## 5. Heating Function Introduction

### 5.1 Detailed Information on the Heating Function Settings Page

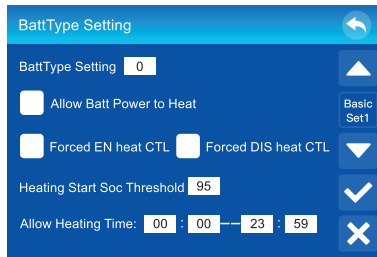

Name	Definition
Allow Batt Power to Heat	Allow Battery Pack to Power Heating Function The heating function supports two power supply paths: battery pack self-power or external inverter power. Checking this option permits the battery pack to supply power to the heating function using its own energy.
Forced EN heat CTL	When the minimum cell temperature meets the activation conditions for the heating function and the heating power supply path is normal, the heating function will be force-enabled. The activation of the heating function is controlled by factors such as the SOC threshold for heating activation, maximum allowed heating time, and minimum cell temperature.
Forced DIS heat CTL	Force Disable Heating Function Checking this option force-disables the heating function by default. If checked while the system is in heating mode, it will immediately exit heating mode and disable the function. When unchecked, the heating function is permitted to operate by default.
Heating Start SOC Threshold	Set the Maximum SOC Threshold for Enabling the Heating Function When Forced EN Heat CTL is not checked: If other conditions for enabling the heating function are met, and the battery pack's SOC $\leq$ the heating activation SOC threshold, the heating function will be enabled. If other conditions for enabling the heating function are met, and the battery pack's SOC $>$ the heating activation SOC threshold, the heating function will not be enabled.
Allow Heating Time	Set the Allowed Heating Function Runtime When Forced EN heat CTL is not checked: If other conditions for enabling the heating function are met, and the current time is within the set allowed heating function runtime, the heating function will be enabled. If other conditions for enabling the heating function are met, and the current time is outside the set allowed heating function runtime, the heating function will not be enabled.

## 5.2 Operating Guidelines for Heating Function Settings

1. Tap the gear icon in the top-right corner of the home screen to access the System Setup page.
2. Tap the Battery Setting icon on the System Setup page to navigate to the BattType Setting page, where you can configure the heating function.

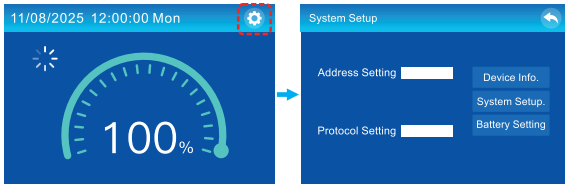

## 5.3 Steps for Heating Mode Configuration

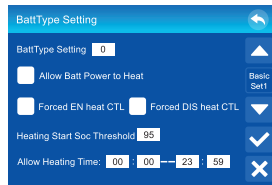

The heating modes of the battery pack can be divided into two types based on the configured heating parameters: Immediate Heating Mode and Strategic Heating Mode.

**Immediate Heating Mode:** The activation and deactivation of the heating function are controlled solely by one factor—the minimum cell temperature.

**Strategic Heating Mode:** The activation and deactivation of the heating function are controlled by the heating parameters configured below this page.

Below are the setup steps for the two heating modes.

### **Immediate Heating Mode:**

1. Check if Forced DIS Heat CTL is unchecked. If it is checked, click to uncheck it.
2. Select whether to check "Allow Batt Power to Heat" based on your requirements for the heating power supply path.
3. Check "Forced EN Heat CTL".
4. Tap the checkmark icon at the bottom-right corner to exit the BattType Setting page and complete the setup for Immediate Heating Mode.

**Strategic Heating Mode:**

1. Check if Forced EN Heat CTL and Forced DIS Heat CTL are unchecked. If either is checked, click to uncheck it.
2. Select whether to check "Allow Batt Power to Heat" based on your requirements for the heating power supply path.
3. Click "Heating Start SOC Threshold" to set the maximum allowed SOC threshold for enabling the heating function.
4. Click "Allow Heating Time" to set the allowed runtime for the heating function.
5. Tap the checkmark icon at the bottom-right corner to exit the BattType Setting page and complete the setup for Strategic Heating Mode.

**5.4 Info Prompt During Battery Pack Heating Operation**

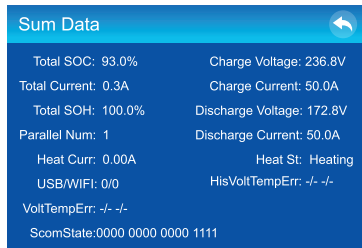

During normal operation of the heating function, the Sum Data Page displays Heat St: Heating (Heat St = Heating Status).

Under any heating mode, if the system detects that the conditions for activating the heating function are met, but the Sum Data Page displays Heat St: "NoHeat" and triggers Alarm 18 or Fault 26, this indicates that the heating function failed to activate properly. The heating function is one of the core features of the battery pack, and its normal operation is critical to the service life and overall performance of the battery pack.

**To ensure safe operation, if you encounter the above abnormalities or have any questions regarding this function, please contact our after-sales service center immediately for professional technical support.**

## 6. Network Device Management

**\*If the entire system uses FelicitySolar products, the battery information can be monitored through the inverter. If paired with inverters from other brands, please follow the steps below:**

### 6.1 Network Configuration

#### 6.1.1 APP Download

Scan the QR code on the right to download the app.



FsolAR APP

#### 6.1.2 Connect to Built-in Wi-Fi Network

Configure your mobile device's WLAN to connect to the built-in Wi-Fi network.

- 1) Launch the app, navigate to the login screen, and tap [Set Up Network] to access the network configuration page.
- 2) On the network configuration page, tap [Switch] to open the mobile device's WLAN settings.

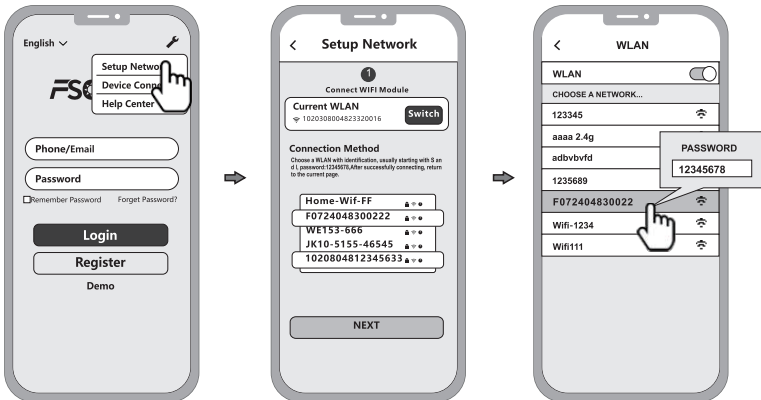

On your mobile device's WLAN settings page, locate the wireless network corresponding to the Smart WiFi Module. Its SSID starts with "F" (e.g., Fxxxxxxxxxxxxxxxx, where "xxxxxxxxxxxxxxxx" matches the device serial number). Enter the module's wireless network password (default: 12345678) to connect to the built-in Wi-Fi network.

### 6.1.3 Network Configuration Steps

- 1) Once your mobile device's WLAN is connected to the built-in Wi-Fi network, return to the app's network configuration page and tap [NEXT] to access the Wi-Fi network page.
- 2) On the Wi-Fi network page, select the router's wireless network that the built-in Wi-Fi needs to connect to, or directly enter the router name. Input the router's wireless password and tap [NEXT].
- 3) Allow time for the built-in Wi-Fi to connect to the router's wireless network. If issues arise, use the app's diagnostic function or refer to the troubleshooting appendix for solutions.

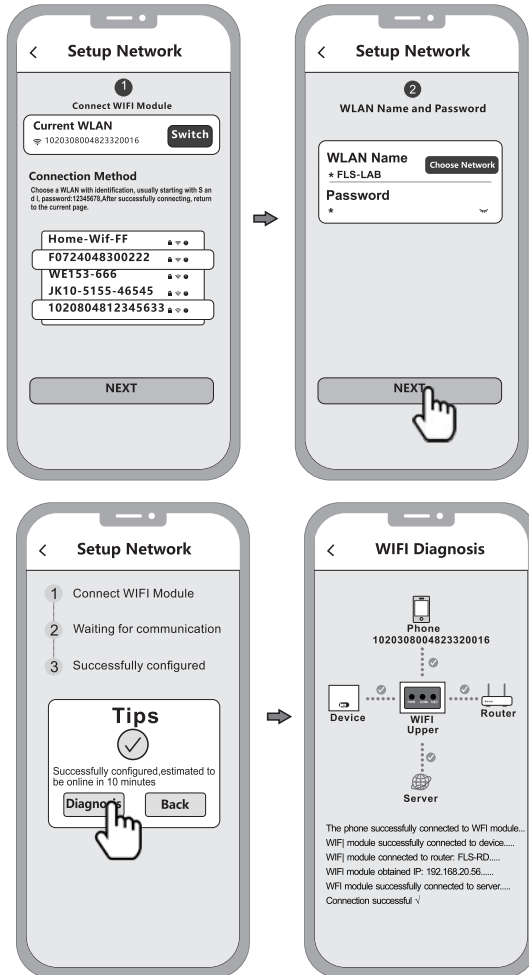

## 6.2 Plant Creation

After the Built-in WIFI is connected to the server, it will transmit the data of the device to the server. And after the plant is created, users can view and manage the device via the APP or web browser.

### 6.2.1 Device Management via APP

#### 1) Register an account

Run the app, enter the login page, click the [Register] button, select the role you want to register, enter and fill in the relevant information (optional email) to register.

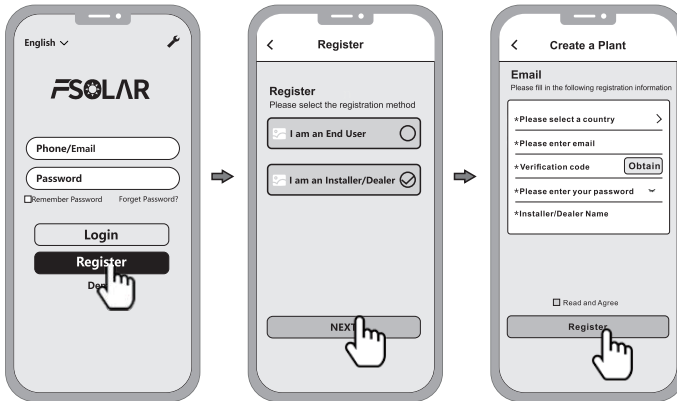

#### 2) New plant construction

- Log in with the newly registered account, enter the homepage, and click on [ Create A Plant ]

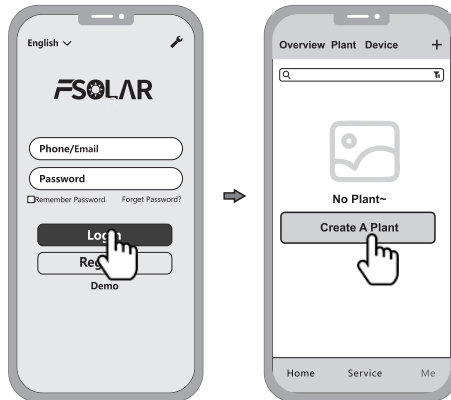

- Fill in the corresponding information and click [OK]
- Click [Add device], click the above icon [scan, align the bar code/two-dimensional code on the side of the inverter or battery pack to scan, or fill in the SN and activation code on the label.

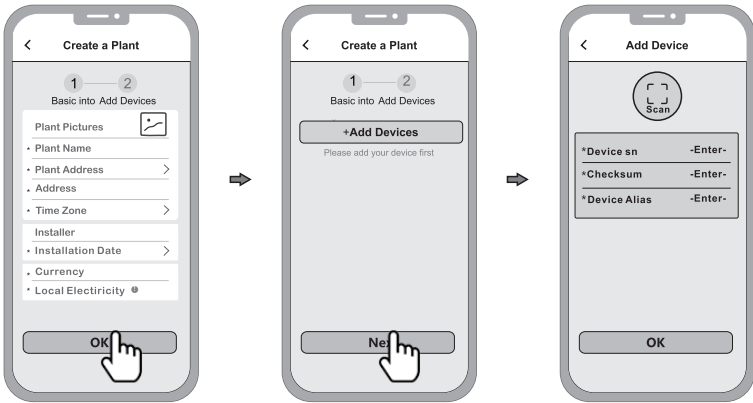

- Manage the device via a web browser, please refer to: <https://shine.felicitysolar.com>

## 7 Maintenance Troubleshooting

### 7.1 Analysis and Treatment of Common Faults

#	Fault Phenomenon	Reason Analysis	Solution
1	Unable to communicate with the inverter	The wrong communication harness was used	Check the communication port definition and use the correct communication harness to connect the battery and the inverter.
2	BMU address allocation failure, the number of BMU is abnormal	Poor contact of the connectors between battery modules; Low software version, insufficient anti-interference ability.	After powering off, shake the battery and then recharge it to confirm. The BCU and BMU communicate one-on-one to identify which BMU has the problem; Contact the supplier to upgrade to the latest version of the software;
3	Cell overvoltage failure	When the SOC reaches 100%, the inverter still charges the battery with a small current, causing the battery cells to over-voltage.	Contact the inverter supplier to upgrade the inverter.
4	Inaccurate SOC display	The battery's SOC has not been calibrated.	The SOC will automatically calibrate after one full charge cycle. First, discharge the battery to 0%, then charge it to 100%.
5	SOC fluctuation, capacity not meeting standards	Low software version, insufficient anti-interference ability; During operation, the BMU was replaced or added.	Contact the supplier to upgrade to the latest version of the software; If there has been any replacement or addition of the BMU during the operation, please contact the supplier for capacity balancing.
6	F3&F4 The voltage difference between adjacent battery cells is extremely large	The voltage sampling harness of the battery cell became loose, resulting in abnormal sampling.	Contact the supplier for repair.
7	F8 Cell over temperature fault	The temperature sampling harness of the battery cell became loose, resulting in abnormal sampling.	Contact the supplier for repair.
8	F13 slave communication fault	Poor contact of the connectors between battery modules: Low software version, insufficient anti-interference ability	After powering off, shake the battery and then recharge it to confirm. The BCU and BMU communicate one-on-one to identify which BMU has the problem; Contact the supplier to upgrade to the latest version of the software;

9	F17 Parallel fault	<p>Poor contact of the connectors between battery cluster, Battery cluster address setting repeatedly;          Low software version, insufficient anti-interference ability</p>	<p>Check whether the communication harness is properly connected. According to 4.3.4 requirements, each BCU address cannot be set repeatedly, and the maximum setting is 16. Contact the supplier to upgrade to the latest version of the software;</p>
---	--------------------	--	---

## 7.2 Fault Code Table

Fault Code	Explain	Tretment Measure
01	High Battery Voltage	Stop charging
02	Low Battery Voltage	Stop discharging
03	High Cell Voltage	Stop charging
04	Low Cell Voltage	Stop discharging
05	High Charging Current	Reduce charging current
06	High Discharging Current	Reduce discharging current
07	High Bms Temperature	Stop charging and discharging ,wait for the temperature to drop
08	Low Bms Temperature	Wait for temperature rise
09	High Cell Temperature	Stop charging and discharging , wait for the temperature to drop
10	Low Cell Temperature	Wait for temperature rise
11	Afe fault	Restart,if the fault stil exists, contact our engineer
12	Soft Start Failed	Restart,if the fault stil exists, contact our engineer
13	Slave Communication Failure	Check for poor contact of the communication line
14	Low Output Impedance	Restart,if the fault stil exists, contact our engineer
15	Slave Version Fault	Contact ourengineer to upgrade the program
16	Slave Device Version Fault	Contact ourengineer to upgrade the program
17	Parallel Fault	<ol style="list-style-type: none"> <li>1. Please check if the number of parallel battery slave controls is the same</li> <li>2. Please check if a single unit is installed in a parallel system</li> <li>3.If this error occurs during parallel installation, please check the wiring. If they are connected correctly, please install them in parallel first and then restart the device.</li> <li>4.If the problem persists, please contact the installation personnel.</li> </ol>
18	Relay Adhesion Fault	Restart,if the fault stil exists, contact our engineer

## 8. Battery Recycling

Aluminum, copper, lithium, iron, and other metal materials are extracted from discarded LiFePO<sub>4</sub> batteries using an advanced hydrometallurgical process, achieving a comprehensive recovery efficiency of up to 80%. The detailed process steps are outlined as follows.

### 8.1 Cathode Material Recycling Process and Steps

The aluminum foil used as a current collector is an amphoteric metal. Initially, it is dissolved in an NaOH alkaline solution, which allows aluminum to enter the solution as NaAlO<sub>2</sub>. After filtration, the filtrate is neutralized using a sulfuric acid solution, leading to the precipitation of Al(OH)<sub>3</sub>. When the pH exceeds 9.0, most of the aluminum precipitates, and the resulting Al(OH)<sub>3</sub> can meet chemical-grade purity specifications upon analysis.

The filter residue is treated with sulfuric acid and hydrogen peroxide, which allows lithium iron phosphate to dissolve into the solution as Fe<sub>2</sub>(SO<sub>4</sub>)<sub>3</sub> and Li<sub>2</sub>SO<sub>4</sub>, while separating it from carbon black and the carbon coating on lithium iron phosphate. After filtration, the pH of the filtrate is adjusted using NaOH and ammonia solution. Iron is first precipitated as Fe(OH)<sub>3</sub>; subsequently, the remaining solution is treated with a saturated Na<sub>2</sub>CO<sub>3</sub> solution at 90°C to induce precipitation.

### 8.2 Anode Material Recycling

The recovery process for anode materials is rather straightforward. Upon separation of the anode plates, the copper achieves a purity exceeding 99%, qualifying it for further refining into electrolytic copper.

### 8.3 Diaphragm Recycling

The diaphragm material is primarily non-hazardous and holds no recycling value.

### 8.4 Recycling Equipment List

Automatic dismantling machine, pulverizes, wet gold pool, etc.

## 9. Disposal

Please abide by the regulations for the disposal of used batteries. Damaged batteries must be stopped immediately. Before disposal, please contact the installer or sales partner and ensure that the batteries are kept away from moisture and direct sunlight.

For details on battery module processing, please contact us in a timely manner:

E-mail: [technicalsupport@felicitysolar.com](mailto:technicalsupport@felicitysolar.com)

Web: <https://www.felicitysolar.com>



### Caution:

1. Do not discard batteries (including rechargeable batteries) as household garbage! According to regulatory requirements, you are obligated to hand over used batteries and rechargeable batteries to the designated recycling channels for disposal.
2. If used batteries are not properly disposed of, they may release pollutants, posing a threat to the environment and health. Improper storage or handling may lead to the leakage of harmful substances.
3. Batteries contain recyclable resources such as iron and lithium, and recycling them can achieve circular value.









Don't regard batteries as household garbage!



## Appendix I: Specifications



Model	FLH96050SG2/FLH96050SG2-H				
Battery Type	LiFePO4				
Module Energy	5.12kWh				
Module Nominal Voltage	102.4V				
Module Capacity	50Ah				
Number of Battery Modules	2	3	4	5	6
System Energy	10.24kWh	15.36kWh	20.48kWh	25.6kWh	30.72kWh
System Usable Energy	9.21kWh	13.82kWh	18.43kWh	23.04kWh	27.64kWh
System Nominal Voltage	204.8V	307.2V	409.6V	512V	614.4V
System Operating Voltage	185.6-230.4V	278.4-345.6V	371.2-460.8V	464-576V	556.8-691.2V
Recommend Charge/Discharge current	25A	25A	25A	25A	25A
Max. continuous charge/discharge current[1]	50A	50A	50A	50A	50A
Depth of discharge(DoD)	90%				
Display type	LED+LCD(Touch)				
IP Rating of Enclosure	IP65				
Operating Temperature Range	Charge:0~+55°C/Discharge:-20°C~+55°C				
Storage Temperature Range	0°C~+35°C				
Humidity	5%~95%				
Altitude	≤2000m				
Cycle Life[2]	≥6000 Cycles				
Installation	Stacking-Mounting/Floor-Mounting				
Protection	Built-in smart BMS, Breaker				
Communication Port	RS485/CAN				
Warranty Period[3]	10 Year				
Control Module FLH96050SCG2 FLH96050SCG2-H	Net Weight	12.5 kg			
	Gross Weight(with base)	24.5 kg			
	Product Dimension	600x385x200 mm			
	Package Dimension(with base)	712x497x352 mm			
Battery Module FLH96050SMG2 FLH96050SMG2-H	Battery Designation[4]	IFpP/41/150/102/[(1P32S)NS]M/-10+50/90			
	Net Weight	57.5kg			
	Gross Weight	62kg			
	Product Dimension	600x385x260 mm			
Package Dimension(with base)	712x497x378 mm				
[1] Max. continuous charge/discharge current is affected by temperature and SOC					
[2] Test conditions: 0.2C Charging/Discharging @25°C, 80% DOD					
[3] Conditions apply, refer to Felicitysolar Warranty policy.					
[4] "N" means the number of battery packs connected series and should not exceed 6.(N≤6)					



## Appendix II: Labels



 	
High Voltage Battery Cluster Controller	
Model	FLH960505CG2
Nominal Voltage	185.6-691.2V
Nominal Charge/Discharge Current	50A
Communication	RS485/CAN
Cycle Life	≥5000
IP Rating of Enclosure	IP65
Protective Class	I
Charging Temperature Range	0-55°C
Discharging Temperature Range	-20-55°C
	



 	
Lithium Iron Phosphate Battery	
Model	FLH960505MG2
Nominal Voltage	102.4V
Nominal Capacity	50Ah
Nominal Energy	5.12kWh
IP Class	IP65
Protective Class	I
Charging Temperature Range	0-55°C
Discharging Temperature Range	-20-55°C
Maximum Continuous Charge/Discharge Current	50A
Nominal Operating Voltage Range	92.8-115.2V
IFpP/41/150/102[(1P32S)M]-10+50/90	
	



 	
Lithium Iron Phosphate Battery System	
Model	FLH960505G2M2
Nominal Voltage	204.8V
Nominal Capacity	50Ah
Nominal Energy	10.24kWh
IP Class	IP65
Protective Class	I
Charging Temperature Range	0-55°C
Discharging Temperature Range	-20-55°C
Maximum Continuous Charge/Discharge Current	50A
Nominal Operating Voltage Range	185.6-230.4V
IFpP/41/150/102[(1P32S)2S]M-10+50/90	
	



 	
Lithium Iron Phosphate Battery System	
Model	FLH960505G2M3
Nominal Voltage	307.2V
Nominal Capacity	50Ah
Nominal Energy	15.36kWh
IP Class	IP65
Protective Class	I
Charging Temperature Range	0-55°C
Discharging Temperature Range	-20-55°C
Maximum Continuous Charge/Discharge Current	50A
Nominal Operating Voltage Range	278.4-345.6V
IFpP/41/150/102[(1P32S)3S]M-10+50/90	
	



 	
Lithium Iron Phosphate Battery System	
Model	FLH960505G2M4
Nominal Voltage	409.6V
Nominal Capacity	50Ah
Nominal Energy	20.48kWh
IP Class	IP65
Protective Class	I
Charging Temperature Range	0-55°C
Discharging Temperature Range	-20-55°C
Maximum Continuous Charge/Discharge Current	50A
Nominal Operating Voltage Range	371.2-460.8V
IFpP/41/150/102[(1P32S)4S]M-10+50/90	
	



 	
Lithium Iron Phosphate Battery System	
Model	FLH960505G2M5
Nominal Voltage	512V
Nominal Capacity	50Ah
Nominal Energy	25.6kWh
IP Class	IP65
Protective Class	I
Charging Temperature Range	0-55°C
Discharging Temperature Range	-20-55°C
Maximum Continuous Charge/Discharge Current	50A
Nominal Operating Voltage Range	464-576V
IFpP/41/150/102[(1P32S)5S]M-10+50/90	
	



 	
Lithium Iron Phosphate Battery System	
Model	FLH960505G2M6
Nominal Voltage	614.4V
Nominal Capacity	50Ah
Nominal Energy	30.72kWh
IP Class	IP65
Protective Class	I
Charging Temperature Range	0-55°C
Discharging Temperature Range	-20-55°C
Maximum Continuous Charge/Discharge Current	50A
Nominal Operating Voltage Range	556.8-691.2V
IFpP/41/150/102[(1P32S)6S]M-10+50/90	
	



 High Voltage Battery Cluster Controller	
Model	FLH96050SCG2-H
Nominal Voltage	185.6-691.2V
Nominal Charge/Discharge Current	50A
Communication	RS485/CAN
Cycle Life	≥6000
IP Rating of Enclosure	IP65
Protective Class	I
Charging Temperature Range	0-55°C
Discharging Temperature Range	-20--55°C
	



 Lithium Iron Phosphate Battery	
Model	FLH96050SMG2-H
Nominal Voltage	102.4V
Nominal Capacity	50Ah
Nominal Energy	5.12kWh
IP Class	IP65
Protective Class	I
Charging Temperature Range	0-55°C
Discharging Temperature Range	-20--55°C
Maximum Continuous Charge/ Discharge Current	50A
Nominal Operating Voltage Range	92.8-115.2V
IFP/P41/150/102[(1P32S)M]-10+50/90	
	

 Lithium Iron Phosphate Battery System	
Model	FLH96050SG2M2-H
Nominal Voltage	204.8V
Nominal Capacity	50Ah
Nominal Energy	10.24kWh
IP Class	IP65
Protective Class	I
Charging Temperature Range	0-55°C
Discharging Temperature Range	-20--55°C
Maximum Continuous Charge/ Discharge Current	50A
Nominal Operating Voltage Range	92.8-115.2V
IFP/P41/150/102[(1P32S)2S]M-10+50/90	
	

 Lithium Iron Phosphate Battery System	
Model	FLH96050SG2M3-H
Nominal Voltage	307.2V
Nominal Capacity	50Ah
Nominal Energy	15.36kWh
IP Class	IP65
Protective Class	I
Charging Temperature Range	0-55°C
Discharging Temperature Range	-20--55°C
Maximum Continuous Charge/ Discharge Current	50A
Nominal Operating Voltage Range	278.4-345.6V
IFP/P41/150/102[(1P32S)3S]M-10+50/90	
	

 Lithium Iron Phosphate Battery System	
Model	FLH96050SG2M4-H
Nominal Voltage	409.6V
Nominal Capacity	50Ah
Nominal Energy	20.48kWh
IP Class	IP65
Protective Class	I
Charging Temperature Range	0-55°C
Discharging Temperature Range	-20--55°C
Maximum Continuous Charge/ Discharge Current	50A
Nominal Operating Voltage Range	371.2-460.8V
IFP/P41/150/102[(1P32S)4S]M-10+50/90	
	

 Lithium Iron Phosphate Battery System	
Model	FLH96050SG2M5-H
Nominal Voltage	512V
Nominal Capacity	50Ah
Nominal Energy	25.6kWh
IP Class	IP65
Protective Class	I
Charging Temperature Range	0-55°C
Discharging Temperature Range	-20--55°C
Maximum Continuous Charge/ Discharge Current	50A
Nominal Operating Voltage Range	464-576V
IFP/P41/150/102[(1P32S)5S]M-10+50/90	
	

 Lithium Iron Phosphate Battery System	
Model	FLH96050SG2M6-H
Nominal Voltage	614.4V
Nominal Capacity	50Ah
Nominal Energy	30.72kWh
IP Class	IP65
Protective Class	I
Charging Temperature Range	0-55°C
Discharging Temperature Range	-20--55°C
Maximum Continuous Charge/ Discharge Current	50A
Nominal Operating Voltage Range	556.8-691.2V
IFP/P41/150/102[(1P32S)6S]M-10+50/90	
	

## Appendix III: SN Description

### 1. High-Voltage Battery Control Unit SN Description

#### For example

FLH96050SCG2 SN: 140509605025019999

FLH96050SCG2-H SN:140609605025019999

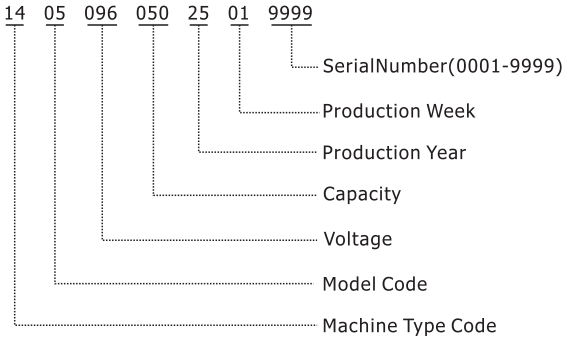

**Note:** The SN code of the main controller is the SN code of the entire system.

### 2. High-Voltage Battery module SN Description

#### For example

FLH96050SMG2 SN: 076309605025019999

FLH96050SMG2-H SN:075409605025019999

